

Improving Energy Efficiency in Sugar Plant Utilities

11 Sep 2024

Hyderabad

Amit Sadachar

DGM – Sales (South & Central Region)

I & AS Business Unit



We engineer dreams

SUMMARY

1. Global Footprint
2. Bonfiglioli in India
3. Product Range
4. Various Applications in Sugar Sector and Offerings
5. Technical Comparison
6. Other Important Projects

We engineer dreams

About Bonfiglioli



A GLOBAL
FAMILY
COMPANY

Our worldwide Presence

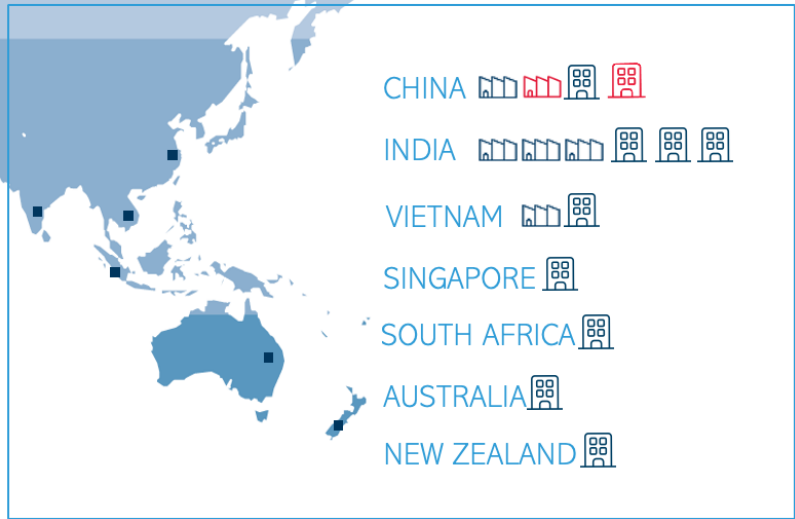
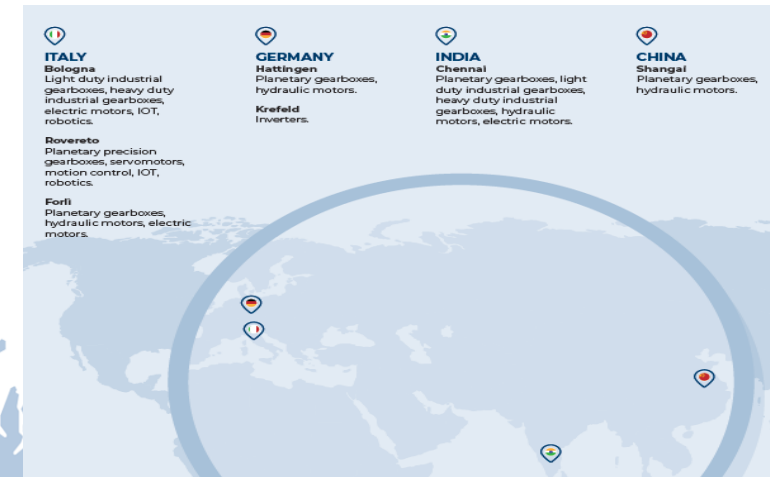
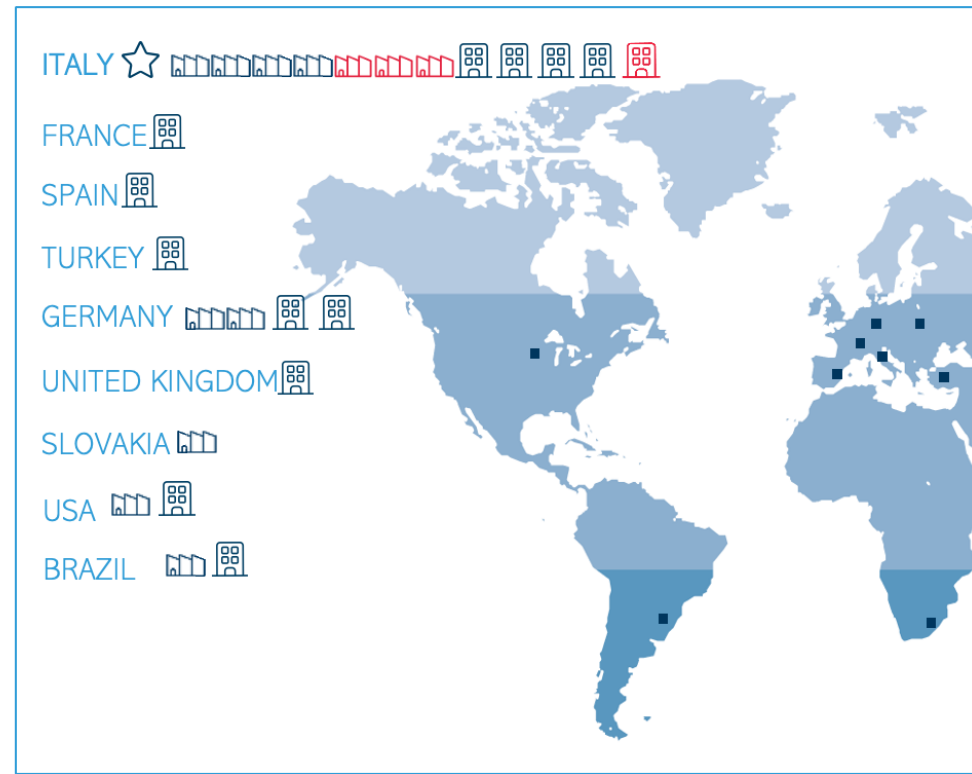

Global R&D Centers

Italy	-3
Germany	-2
India	-1
China	-1

ONE-STOP SHOP AUTOMATION PARTNER

EXPERTISE FOR CUSTOMIZED SOLUTIONS

Our Business Areas and Drivers

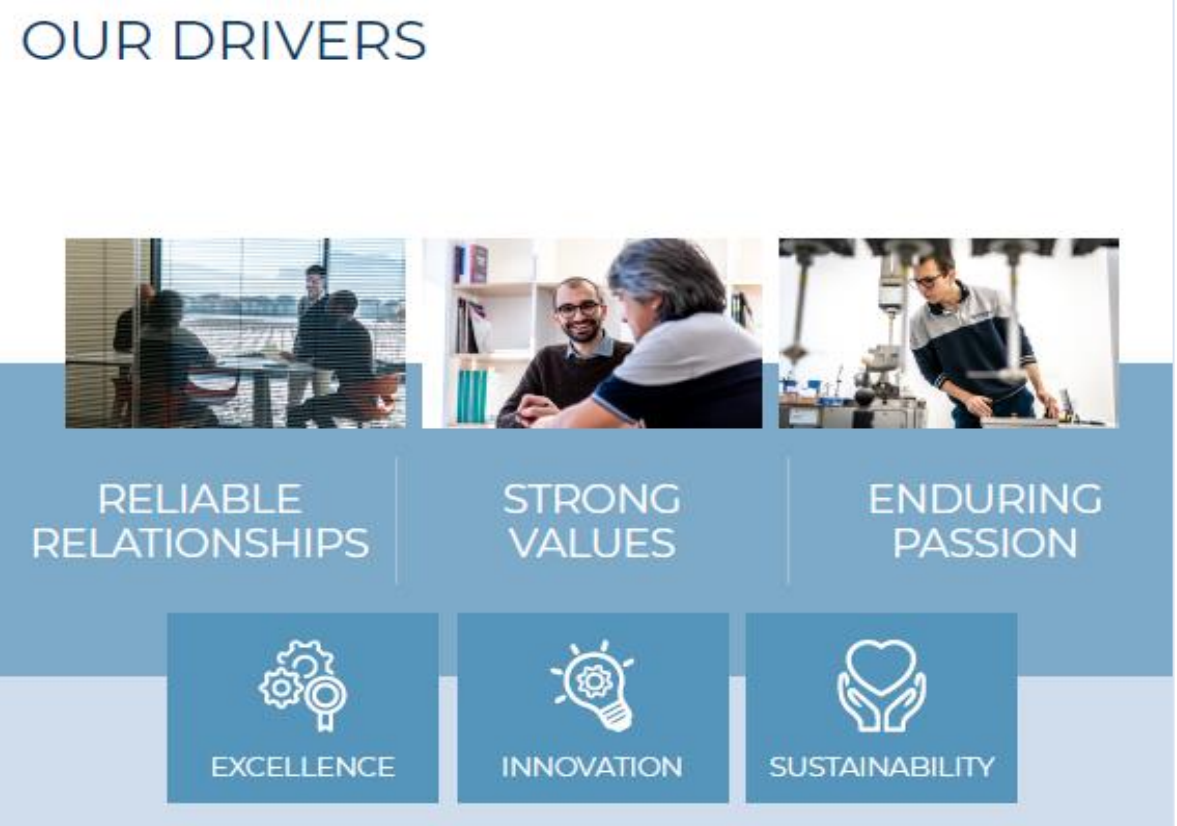

OUR BUSINESS AREAS

INDUSTRY & AUTOMATION SOLUTIONS

The Industry & Automation Solutions business area meets the evolving needs of industrial processes and automation. With a focus on **innovation** and **sustainability**, we operate advanced Industry 4.0 facilities to **serve over 20 industries**. We provide dynamic solutions that address today's complex challenges while driving progress and creating enduring value for customers.

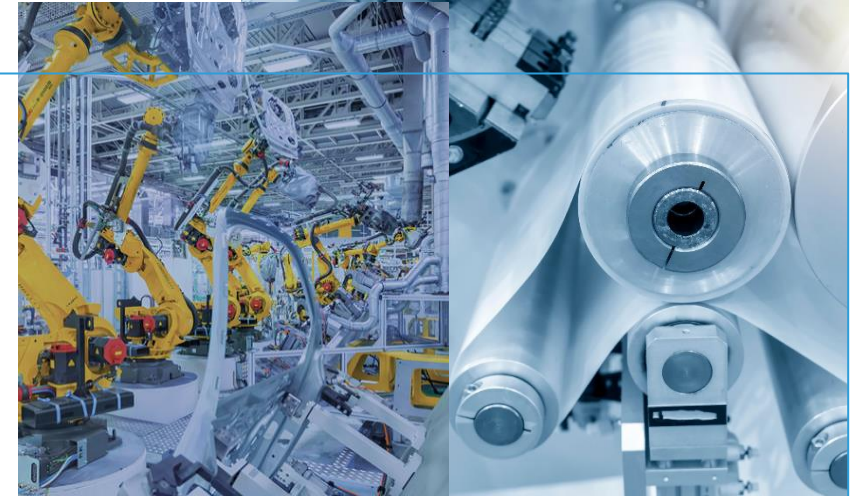

MEET OUR CUSTOMERS' NEEDS



GLOBAL DISTRIBUTION NETWORK



IMPROVE APPLICATION PERFORMANCE



CO-ENGINEERING DEVELOPMENT



PROJECT COMMISSIONING



MAINTENANCE & SERVICES

MAIN SECTORS WHERE WE PROVIDE EXPERTISE:



MATERIAL HANDLING



LOGISTICS AND STOCKING SYSTEMS



FOOD, BEVERAGE AND TOBACCO



CRANES AND WINCHES



MATERIAL WORKING



RECYCLING & ENVIRONMENTAL SUSTAINABILITY



AGGREGATES BUILDING & CONSTRUCTION



PACKAGING & LABELLING



MINING



BIOGAS



TEXTILES



ROBOTICS



CONVEYING



OUR BUSINESS AREAS

MOBILITY & WIND INDUSTRIES

MOBILE SOLUTIONS

Final drives with the **widest torque range on the market**, from 1000 to over 3 million Nm.



SUPPORTING OUR CUSTOMERS IN THE TRANSITION TO ELECTRIC



REDUCED EV KNOWLEDGE AND VEHICLE MODIFICATIONS



REDUCED TIME TO MARKET



REDUCED TIME TO MARKET



> 80% OF WEIGHT AND VOLUME REDUCTION

40 OVER 40 YEARS OF EXPERIENCE

LOCALIZED PRODUCTION

GLOBAL NETWORK



EARTH MOVING



ROAD CONSTRUCTION



MATERIAL HANDLING



AGRICULTURE



MINING



CONSTRUCTION

WIND SOLUTIONS

Undisputed **worldwide leader** with a market share of over 35% in wind turbine drives.



OFF-SHORE UP TO 15 MW ON-SHORE UP TO 6 MW



SMALL WIND TURBINE

OUR BUSINESS AREAS SELCOM GROUP

Part of The Bonfiglioli's Group
since March 2023



SELCOM IS A MECHATRONIC SERVICE PARTNER DESIGNING AND MANUFACTURING CUSTOM HIGH-TECH ELECTRONIC SOLUTIONS.

E.M.S.
ELECTRONIC
MANUFACTURING
SERVICES

O.D.M.
ORIGINAL DESIGN
MANUFACTURING

MAIN SECTORS WHERE WE PROVIDE EXPERTISE:



HOME &
PROFESSIONAL
APPLIANCES



ELECTRIC MOBILITY
& BATTERY
MANAGEMENT
SYSTEMS



INDUSTRIAL &
AUTOMATION



BIOMEDICAL
& WELLNESS

WHAT CAN WE OFFER?



EXTENSIVE R&D
SUPPORT



SOURCING AND
ASSEMBLY



MANUFACTURING
AND DEVELOPMENT
OF CUSTOM
SOLUTIONS



AFTER SALES
PRODUCT SERVICE
AND SUPPORT



TESTING AND
DIAGNOSTICS

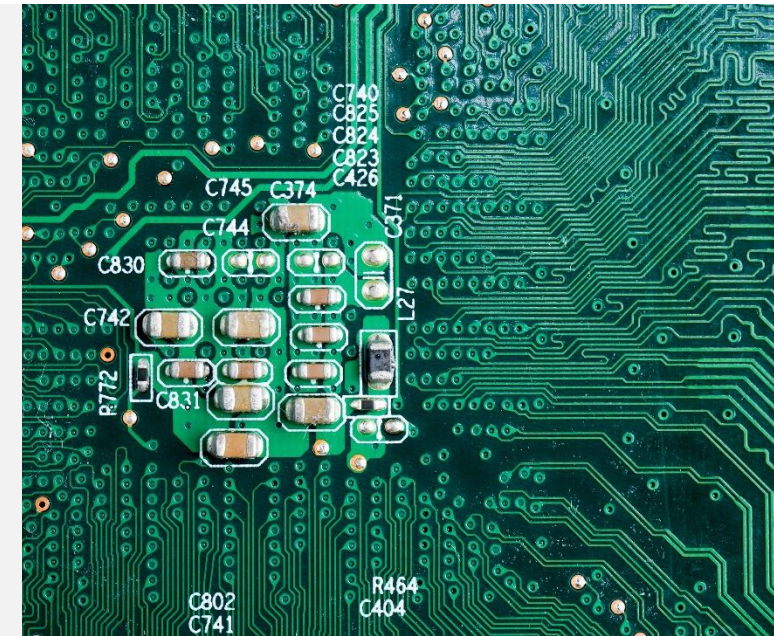

25 Years of Strong Manufacturing Footprint & Leadership Position in India



Chennai- Manufacturing facilities



Chennai- Corporate Office



Pune Campus



Engineered Solutions: Driving India Growth Story



3 State of the Art Factories



All India Service



India Design Centre



>1000 People

Keep the World in Motion



18 Sales Offices



Centre of Excellence-Application

Make in India

- India for India
- India for Global



40 +Sales Partners

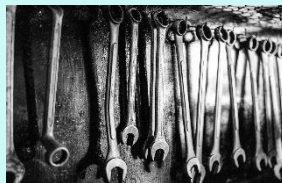

Dedicated After Sales Team

INDUSTRY & AUTOMATION SOLUTIONS RANGE



PLANETARY GEARBOXES



VFD



Torque upto
2.0 Mio NM



LIGHT DUTY (BEVEL,
HELICAL AND WORM)

HEAVY DUTY (BEVEL &
HELICAL)



ELECTRIC MOTORS



SERVO MOTORS & DRIVES



PRECISION GEAR
BOXES



Bonfiglioli Product Range

Gear Motors and Gear Box

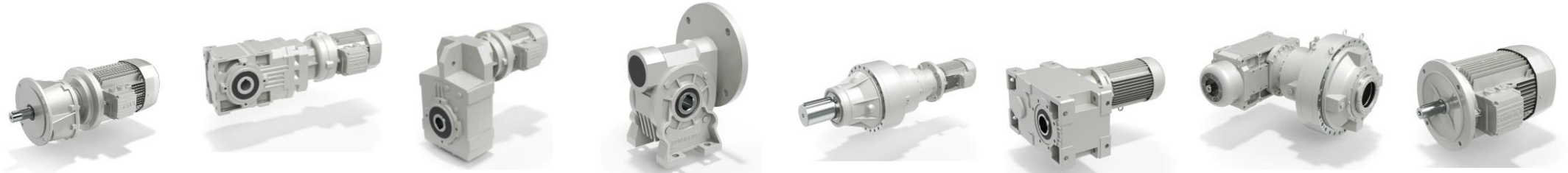

	AS/C	A	F	VF/W	300	HD	Combined	Motors
Type	In-Line Helical	Bevel Helical	Parallel Shaft Helical	Worm	Planetary	Heavy Duty Bevel Helical	Heavy Duty – Planetary / Helical	IE2, IE3, BSR
Torque Range (Nm)	45....12000	100....14000	140..14000	13....7100	1250.... 12,90,000	5190.... 209,900	100,000.... 12,90,000	0.37 22KW
Mech Rating kW @ 1400RPM	0.08..213	0.22..151	0.17..123	0.03..55	0.07 ..200	8.. 2796	10 .. 867	
Ratios	2.6..1481	5.4 ..1715	6.4..2188	7...10000	3.48..5000	7..534	18.1..5234	

Sugar Industry – Various Applications



- Cane Unloader
- Feeder Table
- Cane leveler
- Cane Carrier
- Cane Cutter
- Mill / GRPF
- Inter Rake Carrier
- Bagasse Elevator
- Mechanical Circulator
- Crystallizers
- Stoker Drives
- Clarifiers

OEM & END USER REFERENCE



Cane Unloader



Features	300	HDOP	HF
Arrangement	Inline / Right angle	Helical / Bevel Helical	Helical
Mounting	Foot / Flange	Foot	Flange
Output	Solid / Spline / Wheel flange	Solid	Solid / Spline / Wheel flange
Input shaft	IEC Adaptor / Solid	Solid	IEC adaptor
Motor	Flange / Foot	Foot	Flange
Torque range	1250 - 1286700 Nm	5190 - 210000 Nm	1115 – 5900 Nm
Price	Low	High	Medium



Feeder Table



Key Features

- High transmissible torque / weight ratio
- Combined versions (HD, A, VF/W series)
- Hollow and solid cylindrical and spline shafts
- Wide range of options and accessories
- Electric and hydraulic motor inputs
- Built in cooling fan

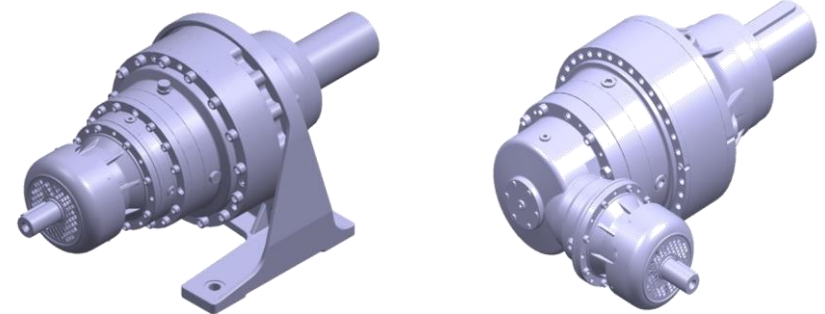

Cane carrier



Key Customer Benefits

- Ideal for slow speed applications
- can go up to or 6 reduction stages
- High torque density
- High output torque
- Low maintenance cost
- Extremely customizable
- High shock resistance

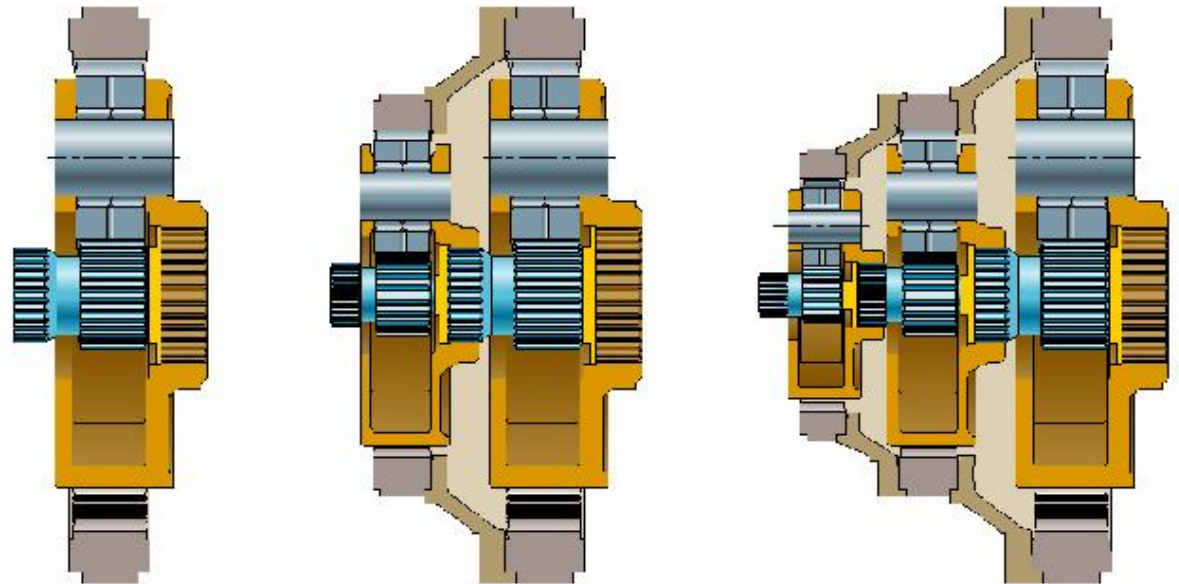

Mill



DATI TECNICI RIDUTTORE - GEARBOX TECHNICAL DATA	
Rapporto di riduzione: <i>Gear ratio:</i>	tot =137.2 :1
Potenza assorbita <i>Assarbed Power</i>	300 kW
Coppia nominale n_2 : <i>Rated torque at:</i> 1200 min ⁻¹	297960 Nm
Coppia nominale n_2 : <i>Rated torque at:</i> 10000	890310 Nm
Coppia nominale n_2 : <i>Rated torque at:</i> 100000	602740 Nm

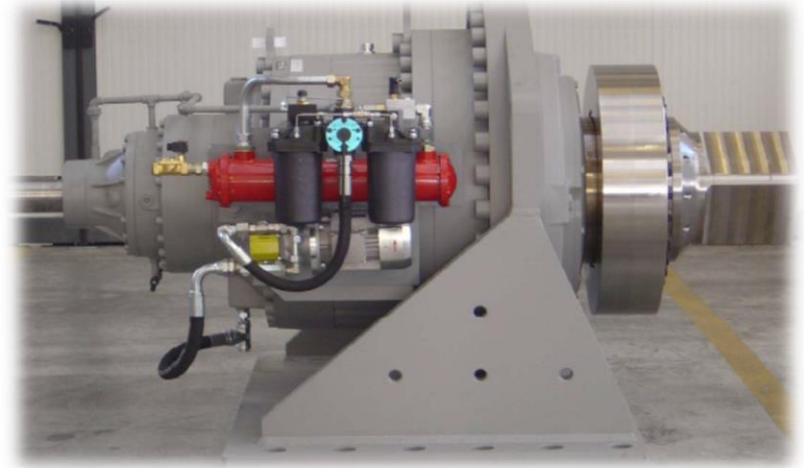

Rake Carriers and Bagasse Elevators



Type	Torque [Nm]
300	1 250
301	2 460
303	2 970
304	3 960
305	5 800
306	10 840
307	15 680
309	23 240
310M	33 460
311M	49 210
313M	60 940
314M	80 640
315M	100 800
316M	134 390
317M	207 490
318M	297 550
319	471 190
321	655 740
323	890 310
325	1 286 000

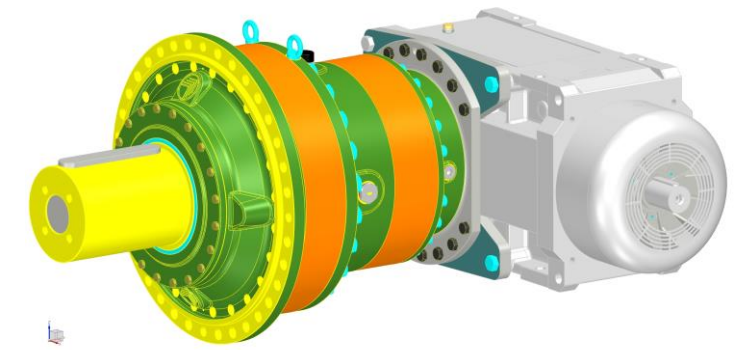
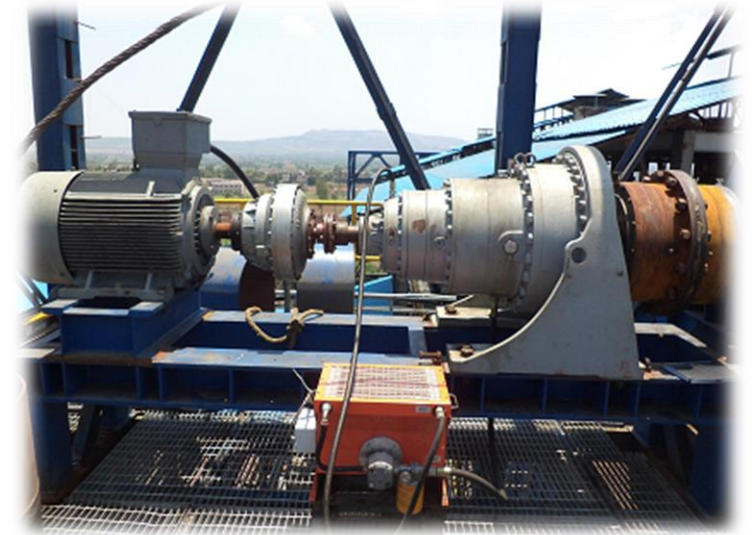

Crystallizer (Horizontal and Vertical)



Key Features

- 5 reduction stages
- Hollow shaft with keyway design
- IEC motor input adaptor
- Suitable torque arm
- Lower product weight
- Highest reliability

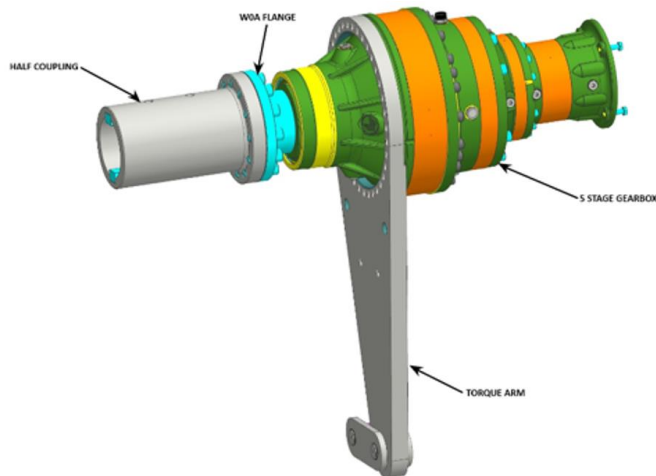

Case Study - Conventional Bevel Helical Vs Planetary

	Equivalent model of Bonfiglioli	Planetary solution (Bonfiglioli)
Model Configuration	HDO 140+ AS 80 + BE 160M 4	3 15 L 4 + TA + BE 160M 4
Ratio	1123	1104
Mn2 (Nm)	87060	94800
Pn1 (kw)	11	11
Weight in kgs (Approx)	2250	800
Oil quantity	100	22
Oil change frequency	12500 h	12500 h
Market Price (Without motor)	1,735,000	1,000,000
Overall life hours (Gears)	> 50000	>50000
Overall life hours (Bearings)	> 50000	>50000
Efficiency	87%	88%
No of stages	6	4

- Planetary gear units weigh lesser and use lesser lubrication oil
- Low initial cost and total cost of ownership

Other Important Projects



Apron Feeder



- Model: 3 17 R4, 3/H 17
- Type – Helical Planetary



Railway Wheel Machining



- Model: A 35 & F 60
- Type – Bevel Helical



Bulk Reception Unit



- Model: 3 11 – 3 17 R4
- Type – Bevel Planetary



Reactors / Agitators



- Model: HDO 120 / 125
- Type - Vertical Helical



Travel Drive



- Model: A 70, 80 and 90
- Type - Helical - Bevel



Desolventizer Toaster



- Model: HDO 180
- Type- Bevel - Helical



Vertical Crystalliser



- Model: 3 18 L5
- Type - Planetary



Spherical Drier



- Model: HDP 150
- Type – Vertical Helical



PSLV 9 - Launching pad



- Model: RAN 18
- Type – Bevel (RAN series)

SOCIAL RESPONSIBILITY



A BETTER FUTURE FOR YOUNG PEOPLE



A BRIDGE BETWEEN SCHOOL AND THE WORLD OF WORK

MUS-E Musique Europe



CheerFutureLand

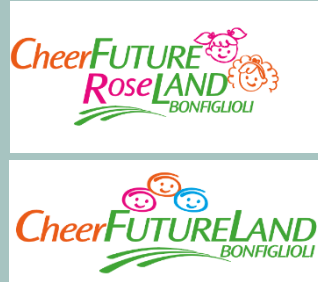

Ho Chi Minh City School



Clementino Bonfiglioli Prize



Malpighi Lab



Ragazze Digitali ER



Develop Engineers for Tomorrow- Set up Mechatronics Lab for Engg. College at Chennai

THANK YOU

We engineer dreams

 **Bonfiglioli**